



ORIGA Pneumatic Linear Drives OSP-L

Very long lifetime and lowest leakage



A **NEW** Modular Linear Drive System

With this second generation linear drive Parker Origa offers design engineers complete flexibility. The well known ORIGA cylinder has been further developed into a combined linear actuator, guidance and control package. It forms the basis for the new, versatile ORIGA SYSTEM PLUS linear drive system.

All additional functions are designed into modular system components which replace the previous series of cylinders.

- Completely modular design
- Compatible with the comprehensive ORIGA OSP system component range
- High loads and moments
- Space saving
- For a wide range of loads, speeds and motion profiles

Introduction – OSP Concept

<p>Basic Linear Drive Standard Version</p> <ul style="list-style-type: none"> • Series OSP-L 	
<p>Air Connection on the End-face or both at One End</p> <ul style="list-style-type: none"> • Series OSP-L 	
<p>Integrated 3/2 Way Valves</p> <ul style="list-style-type: none"> • Series OSP-L 	
<p>Clevis Mounting</p> <ul style="list-style-type: none"> • Series OSP-L 	
<p>End Cap Mounting</p> <ul style="list-style-type: none"> • Series OSP-L 	
<p>Mid-Section Support</p> <ul style="list-style-type: none"> • Series OSP-L 	
<p>Inversion Mounting</p> <ul style="list-style-type: none"> • Series OSP-L 	

<p>Duplex Connection</p> <ul style="list-style-type: none"> • Series OSP-L 	
<p>Multiplex Connection</p> <ul style="list-style-type: none"> • Series OSP-L 	
<p>Linear Guides – SLIDELINE</p> <ul style="list-style-type: none"> • Series OSP-L 	
<p>Linear Guides – STARLINE</p> <ul style="list-style-type: none"> • Series OSP-L 	
<p>Magnetic Switches</p> <ul style="list-style-type: none"> • Series OSP-L 	
<p>Variable Stop VS</p> <ul style="list-style-type: none"> • Series OSP-L with Linear Guide STL 	

Options and Accessories for system versatility

Series OSP-L

STANDARD VERSIONS OSP-L25 to L63

Standard carrier with integral guidance. End cap can be rotated 4 x 90° to position air connection on any side.
Magnetic piston as standard.
Dovetail profile for mounting of accessories and the cylinder itself.

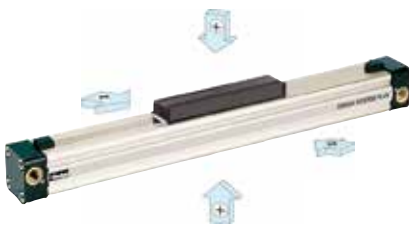

BASIC CYLINDER OPTIONS

The special design of the linear drive enables all emissions to be led away.

STAINLESS VERSION

For use in constantly damp or wet environments. All screws are A2 quality stainless steel (material no.1.4301 / 1.4303)



END-FACE AIR CONNECTION

To solve special installation problems.



BOTH AIR CONNECTIONS AT ONE END

For simplified tubing connections and space saving.



INTEGRATED VOE VALVES

The complete compact solution for optimal cylinder control.



DUPLEX CONNECTION

The duplex connection combines two OSP-L cylinders of the same size into a compact unit with high performance.



MULTIPLEX CONNECTION

The multiplex connection combines two or more OSP-L cylinders of the same size into one unit. The orientation of the carriers can be freely selected.



ACCESSORIES

MAGNETIC SWITCHES TYPE RS, ES, RST, EST

For electrical sensing of end and intermediate piston positions.



MOUNTINGS FOR OSP-L25 TO L63

CLEVIS MOUNTING

Carrier with tolerance and parallelism compensation for driving loads supported by external linear guides.



END CAP MOUNTING

For end-mounting of the cylinder.



MID-SECTION SUPPORT

For supporting long cylinders or mounting the cylinder by its dovetail rails.



INVERSION MOUNTING

The inversion mounting transfers the driving force to the opposite side, e.g. for dirty environments.



Origa System Plus

- Innovation from a proven design

The newly developed product line OSP-L can be simply and neatly integrated into any machine layout.

MOUNTING RAILS ON 3 SIDES

Mounting rails on 3 sides of the cylinder enable modular components such as linear guides, brakes, valves, magnetic switches etc. to be fitted to the cylinder itself. This solves many installation problems, especially where space is limited.

The modular system concept forms an ideal basis for additional customer-specific functions.

Magnetic piston as standard - for contactless position sensing on three sides of the cylinder.

Corrosion resistant steel outer sealing band and robust wiper system on the carrier for use in aggressive environments.

Inner sealing band made of polyurethane for best sealing features and extreme slight friction.

Combined clamping for inner and outer sealing band with dust cover.

Stainless steel screws optional.

Low friction piston seals for optimized running characteristics

End cap can be rotated to any one of the four positions (before or after delivery) so that the air connection can be in any desired position.

Optimized cylinder profile for maximum stiffness and minimum weight. Integral air passages enable both air connections to be positioned at one end, if desired.

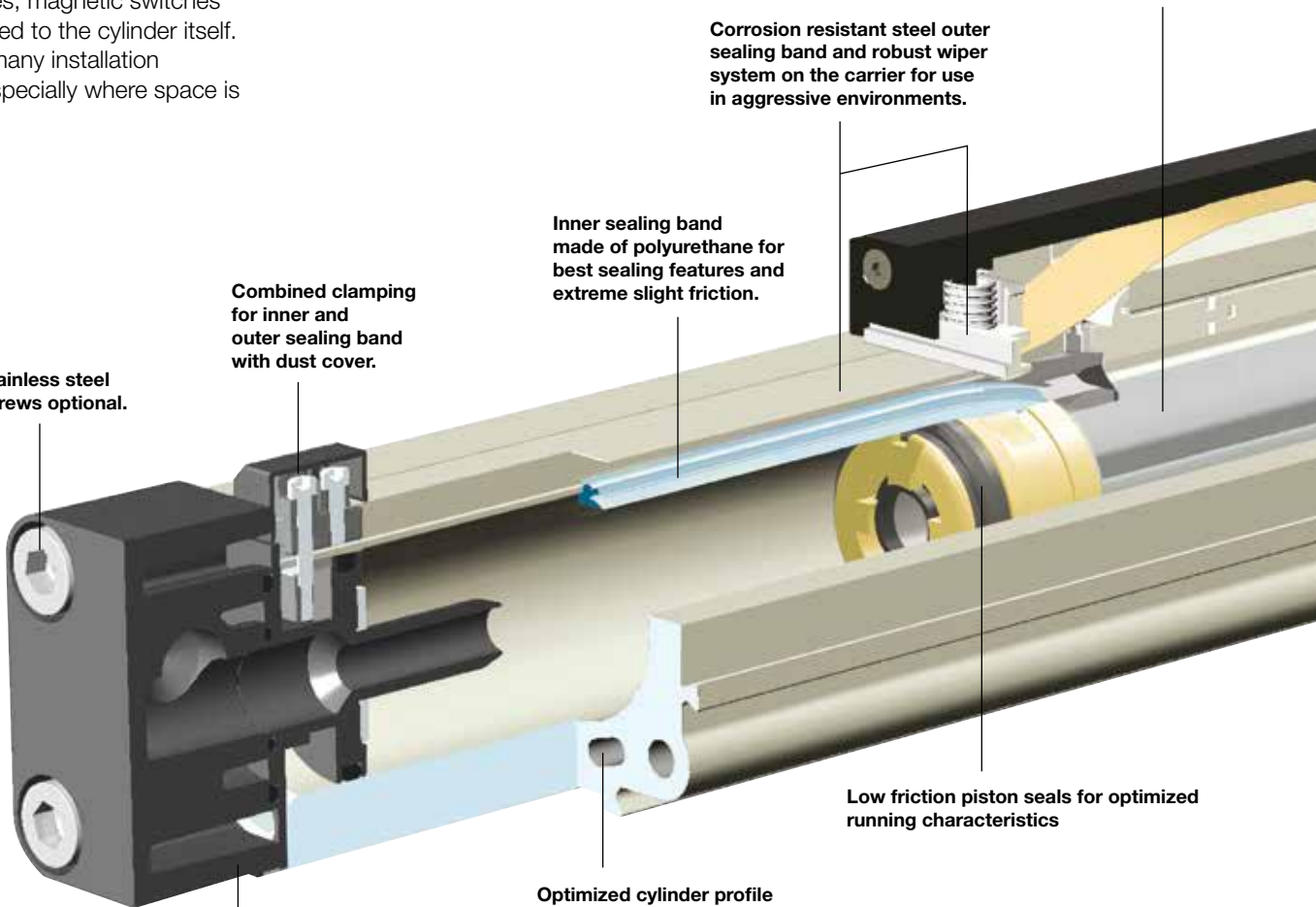

SLIDELINE
 Cost-effective
 plain bearing
 guide for medium
 loads.



STARLINE
 Recirculating ball
 bearing guide for
 very high loads
 and precision.

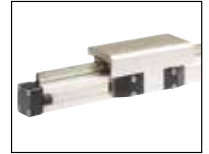

**VARIABLE STOP
 VS**
 The variable stop
 provides simple
 stroke limitation.



**INTEGRATED
 VOE VALVES**
 The complete
 compact solution
 for optimal cylinder
 control.



New low profile
 piston/carrier design.

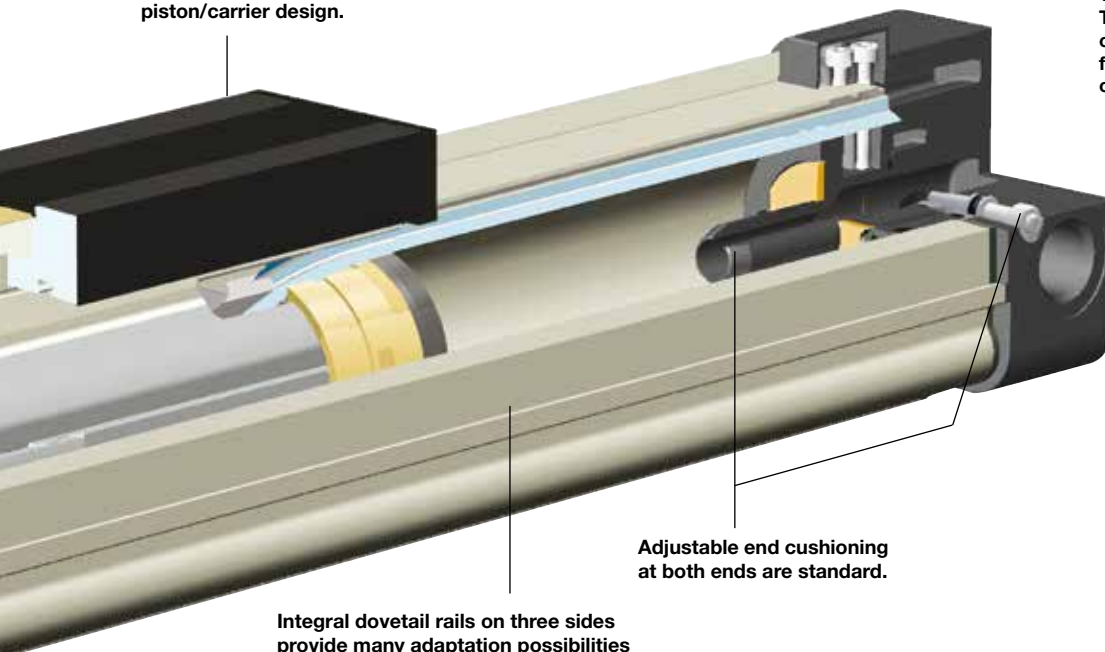

Adjustable end cushioning
 at both ends are standard.

Integral dovetail rails on three sides
 provide many adaptation possibilities
 (linear guides, magnetic switches, etc.)

Modular system components
 are simply clamped on.

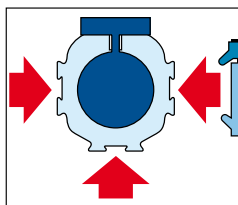

OSP-L Application examples

ORIGA SYSTEM PLUS – rodless linear drives offer maximum flexibility for any application.

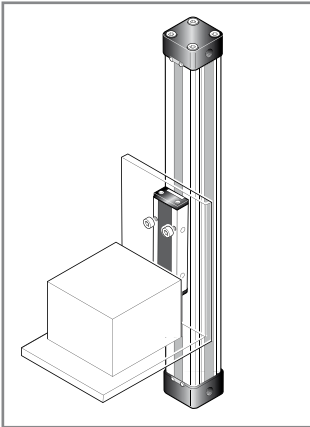

The high load capacity of the piston can cope with high bending moments without additional guides.

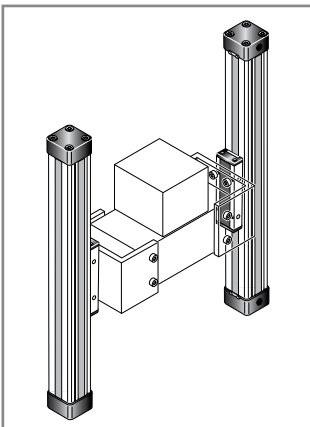

The mechanical design of the OSP-L allows synchronised movement of two cylinders.

Integrated guides offer optimal guidance for applications requiring high performance, easy assembly and maintenance free operation.

Optimal system performance by combining multi-axis cylinder combinations.

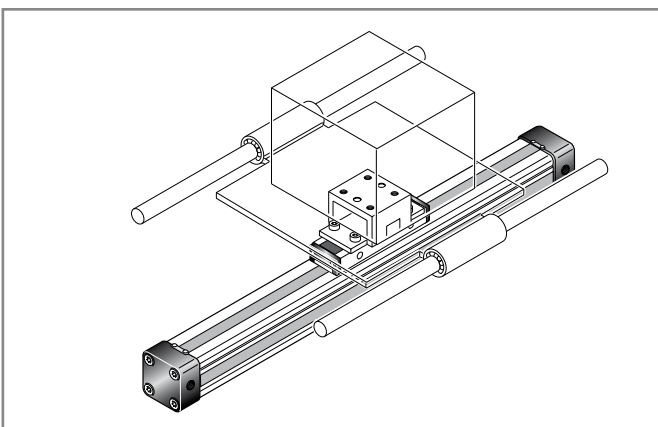

When using external guides, the clevis mounting is used to compensate for deviations in parallelism.

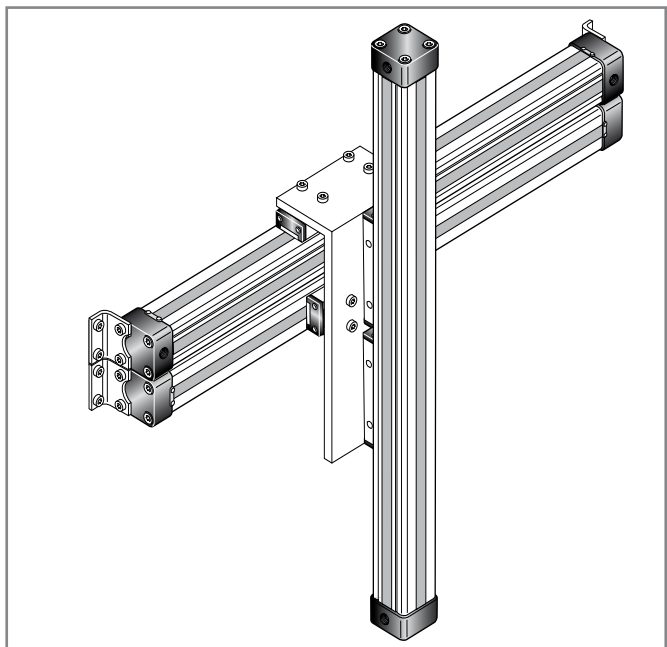

For further information and assembly instructions, please contact your local Parker Origa dealer.

Rodless Pneumatic Cylinder
Ø 25-63 mm

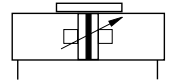

Standard Versions:

- Double-acting with adjustable end cushioning
- With magnetic piston for position sensing



Special Versions:

- Stainless steel screws
- Both air connections on one end
- Air connection on the end-face
- Integrated Valves VOE
- End cap can be rotated 4 x 90° to position air connection as desired
- Free choice of stroke length up to 6000 mm

Size Comparison

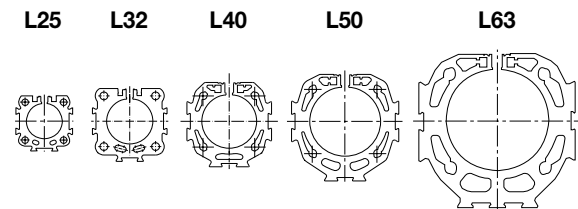

Characteristics	Description
General Features	
Type	Rodless cylinder
Series	OSP-L
System	Double-acting, with cushioning, position sensing capability
Mounting	See drawings
Air Connection	Threaded
Ambient temperature range T_{min} to T_{max}	-20 °C Other temperature ranges +80 °C on request
Installation	In any position
Medium	Filtered, unlubricated compressed air (other media on request)
Lubrication	Permanent grease lubrication (additional oil mist lubrication not required)
Material	
Cylinder Profile	Anodized aluminium
Carrier (piston)	Anodized aluminium
End caps	Aluminium, lacquered
Sealing bands	Corrosion resistant steel (outer band) Polyurethane (inner band)
Seals	Polyurethane, NBR
Screws	Galvanized steel Option: stainless steel
Dust covers, wipers	Plastic
Max. operating pressure p_{max}	8 bar

Loads, Forces and Moments

Choice of cylinder is decided by:

- Permissible loads, forces and moments
- Performance of the pneumatic end cushions.

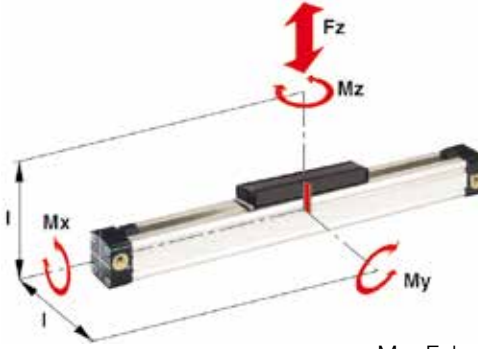

$M = F \cdot l$
Bending moments are calculated from the centre of the linear actuator

The main factors here are the mass to be cushioned and the piston speed at start of cushioning (unless external cushioning is used, e. g. hydraulic shock absorbers).

The adjacent table shows the maximum values for light, shock-free operation, which must not be exceeded even in dynamic operation. Load and moment data are based on speeds $v \leq 0.5$ m/s.

When working out the action force required, it is essential to take into account the friction forces generated by the specific application or load.

Cylinder-Series Ø [mm]	Theoretical Action Force at 6 bar [N]	effektive Action Force F_A at 6 bar [N]	max. Moments			max. Load F [N]	Cushion Length [mm]
			Mx [Nm]	My [Nm]	Mz [Nm]		
OSP-L25	295	250	1.5	15	3	300	17
OSP-L32	483	420	3	30	5	450	20
OSP-L40	754	640	6	60	8	750	27
OSP-L50			in progress				
OSP-L63			in progress				

Cushioning Diagram

Work out your expected moving mass and read off the maximum permissible speed at start of cushioning. Alternatively, take your desired speed and expected mass and find the cylinder size required. Please note that piston speed at start of cushioning is typically ca. 50 % higher than the average speed, and that it is this higher speed which determines the choice of cylinder.

If the permitted values are exceeded, either additional shock absorbers should be fitted in the area of the centre of the gravity or you can consult us about our special cushioning system- we shall be happy to advise you on your specific application.

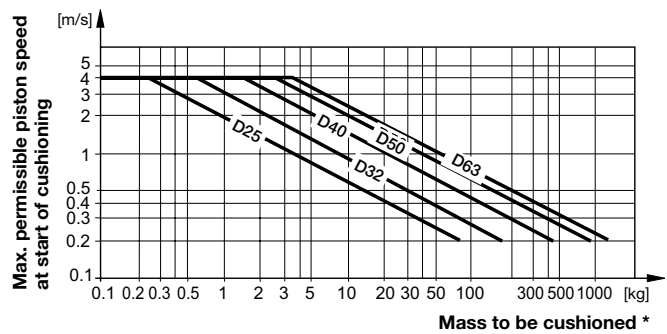

* For cylinders with linear guides or brakes, please be sure to take the mass of the carriage or the brake housing into account.

Weight (mass) [kg]

Cylinder series (Basic cylinder)	Weight (Mass) [kg]	
	At 0 mm stroke	per 100 mm stroke
OSP-L25	0.65	0.197
OSP-L32	1.44	0.354
OSP-L40	1.95	0.415
OSP-L50	in progress	
OSP-L63	in progress	

For further technical information see catalogue P-A4P012GB

Integrated 3/2 Way Valves

VOE

Series OSP-L25, L32, L40 and L50

For optimal control of the OSP-L cylinder, 3/2 way valves integrated into the cylinder's end caps can be used as a compact and complete solution. They allow for easy positioning of the cylinder, smooth operation at the lowest speeds and fast response, making them ideally suited for the direct control of production and automation processes.



Features:

- Complete compact solution
- Various connection possibilities:
Free choice of air connection with rotating end caps with VOE valves, Air connection can be rotated 4 x 90°
- Solenoid can be rotated 4 x 90°
- Pilot valve can be rotated 180°
- High piston velocities can be achieved with max. 3 exhaust ports
- Minimal installation requirements
- Requires just one air connection per valve
- Optimal control of the OSP-L cylinder
- Excellent positioning characteristics
- Integrated operation indicator
- Integrated exhaust throttle valve
- Manual override - indexed
- Adjustable end cushioning
- Easily retrofitted – please note the increase in the overall length of the cylinder!

Characteristics 3/2 Way Valves VOE

Characteristics 3/2 Way Valves with spring return

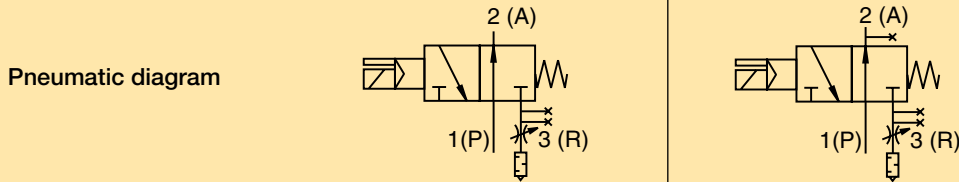

Type	VOE-25	VOE-32	VOE-40	VOE-50
Actuation	electrical			
Basic position	P → A open, R closed			
Type	Poppet valve, non overlapping			
Mounting	integrated in end cap			
Installation	in any position			
Port size	G 1/8	G 1/4	G 3/8	G 3/8
Temperature	-10°C to +50°C *			
Operating pressure	2-8 bar			
Nominal voltage	24 V DC / 230 V AC, 50 Hz			
Power consumption	2.5 W / 6 VA			
Duty cycle	100%			
Electrical Protection	IP 65 DIN 40050			

* other temperature ranges on request

For further technical information see catalogue P-A4P012GB

Order Instructions- Basic Cylinder

1-4	5+6	7	8	9	10	11	12-16	17	18	19	20	21	22	23	24	25
OSPL	25	0	0	0	0	0	01100	0	0	0	0	0	0	0	0	0

Piston-Ø
 25
 32
 40
 in progress
 in progress

Stroke
 in mm
 (5 digits)

Piston Mounting
 0 without
 1 clevis mounting

add. Guide Carriage
 0 without

Measuring system
 0 without

Screws
 0 standard
 1 Stainless

Cushioning
 0 standard
 1 max. length

Version / Piston
 0 standard
 1 Tandem

Lubrication
 0 standard

End cap position
 0 l+r 0° = in front
 1 l+r 90° = under-
 neath
 2 l+r 180° = at the
 back
 3 l+r 270° = same side
 as outerband
 4 l 90° = underneath;
 r 0° = in front
 5 l 180° = at the back;
 r 0° = in front
 6 l 270° = same side
 as outerband;
 r 0° = in front
 7 l 0° = in front;
 r 90° = underneath
 8 l 180° = at the back;
 r 90° = underneath
 9 l 270° = same side
 as outerband;
 r 90° = underneath
 A l 0° = in front;
 r 180° = at the back
 B l 90° = underneath;
 r 180° = at the back
 C l 270° = same side
 as outerband;
 r 180° = at the back
 D l 0° = in front;
 r 270° = same side
 as outerband
 E l 90° = underneath;
 r 270° = same side
 as outerband
 F l 180° = at the back;
 r 270° = same side
 as outerband

Guides / Brakes / Inversion
 0 without
 M Inversion
 Ø 16-80
 N Duplex
 Ø 25,32,40,50

Cover / Cable Channel
 0 standard
 1 Cable channel
 2 Cable channel
 two-sided

Air Connection
 0 standard
 1 end face
 2 both at one end
 3 left standard
 right end face
 4 right standard
 left end face
 A 3/2 Way valve
 VOE 24 V =
 Ø 25,32,40,50
 B 3/2 Way valve
 VOE 230 V~/110 V=
 Ø 25,32,40,50
 C 3/2 Way valve
 VOE 48 V =
 Ø 25,32,40,50
 E 3/2 Way valve
 VOE 110 V~
 Ø 25,32,40,50

Seals
 0 standard

End cap position (air connection)

270° same side as outerband
 180° at the back
 end-face
 0° in front
 90° underneath

Cylinder R (right end side)

270° same side as outerband
 180° at the back
 end-face
 0° in front
 90° underneath

Cylinder L (left end side)

180° at the back
 end-face
 0° in front
 90° underneath

Plain Bearing Guide
SLIDELINE
Series SL 25 to 63 for Linear Drive



Features:

- Anodised aluminium guide rail with prism-shaped slideway arrangement
- Adjustable plastic slide elements
- Composite sealing system with plastic and felt wiper elements to remove dirt and lubricate the slideways
- Corrosion resistant version available on request
- Any length of stroke up to 5500 mm (longer strokes on request)

Loads, Forces and Moments

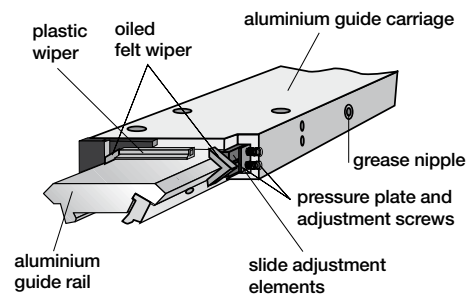
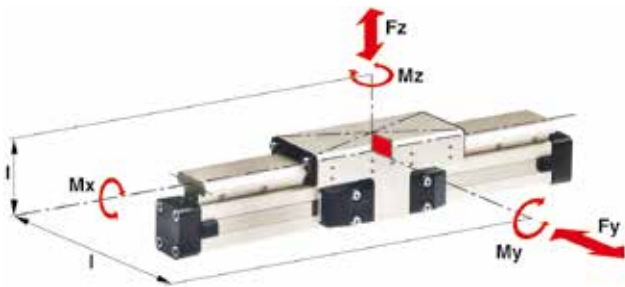

Technical Data

The table shows the maximum permissible values for smooth operation, which should not be exceeded even under dynamic conditions.

The load and moment figures apply to speeds $v < 0.2$ m/s.

*** Please note:**

In the cushioning diagram, add the mass of the guide carriage to the mass to be cushioned.

For further technical information see catalogue P-A4P012GB

Series SL	For linear drive	Max. moments [Nm]			Max. loads [N] Fy, Fz	Mass of linear drive with guide [kg]		Mass * of guide carriage [kg]	Order No. ** SLIDELINE ¹⁾ Guide without cylinder
		Mx	My	Mz		with 0 mm stroke	increase per 100 mm stroke		
SL25	OSP-L25	14	34	34	675	1.55	0.39	0.61	20342FIL
SL32	OSP-L32	29	60	60	925	2.98	0.65	0.95	20196FIL
SL40	OSP-L40	50	110	110	1600	4.05	0.78	1.22	20343FIL
SL50	OSP-L50	in progress							
SL63	OSP-L63								

** Please use this order pattern: Order-No. + "stroke in mm" (5 digits)
 Example: SLIDELINE guide D25mm, stroke 1000mm: 20342-01000

¹⁾ Corrosion resistant fixtures available on request

Order Instructions SLIDELINE

1-4	5+6	7	8	9	10	11	12-16	17	18	19	20	21	22	23	24	25
OSPL	25	0	0	0	0	0	01100	0	0	0	0	0	0	0	0	0

Piston-Ø	
25	
32	
40	
in progress	
in progress	

Stroke	
in mm (5 digits)	

Piston Mounting	
0	without

Measuring system	
0	without

Screws	
0	standard
1	Stainless

Cushioning	
0	standard

Version / Piston	
0	standard
1	Tandem

Lubrication	
0	standard

End cap position	
0	l+r 0° = in front
1	l+r 90° = underneath
2	l+r 180° = at the back
3	l+r 270° = same side as outerband
4	l 90° = underneath; r 0° = in front
5	l 180° = at the back; r 0° = in front
6	l 270° = same side as outerband; r 0° = in front
7	l 0° = in front; r 90° = underneath
8	l 180° = at the back; r 90° = underneath
9	l 270° = same side as outerband; r 90° = underneath
A	l 0° = in front; r 180° = at the back
B	l 90° = underneath; r 180° = at the back
C	l 270° = same side as outerband; r 180° = at the back
D	l 0° = in front; r 270° = same side as outerband
E	l 90° = underneath; r 270° = same side as outerband
F	l 180° = at the back; r 270° = same side as outerband

Guides/ Brakes/ Inversion	
0	without
2	Slideline SL Ø 25-63

Cover / Cable Channel	
0	standard
1	Cable channel
2	Cable channel two-sided

Air Connection	
0	standard
1	end face
2	both at one end
3	left standard right end face
4	right standard left end face
A	3/2 Way valve VOE 24 V = Ø 25,32,40,50
B	3/2 Way valve VOE 230 V~/110 V= Ø 25,32,40,50
C	3/2 Way valve VOE 48 V = Ø 25,32,40,50
E	3/2 Way valve VOE 110 V~ Ø 25,32,40,50

Seals	
0	standard

add. Guide Carriage	
0	without
2	Guide Carriage Slideline SL Ø 25-63

End cap position (air connection)

270° same side as outerband

180° at the back

end-face

0° in front

90° underneath

Cylinder R (right end side)

Cylinder L (left end side)

**Recirculating Ball Bearing Guide
 STARLINE
 Series STL 16 to 50 for Linear Drive**



Features:

- Polished and hardened steel guide rail
- For very high loads in all directions
- High precision
- Integrated wiper system
- Integrated grease nipples
- Any length of stroke up to 3700 mm
- Anodized aluminium guide carriage
 – dimensions compatible with OSP guides SLIDELINE
- Installation height (STL25 - 32) compatible with OSP-L guides SLIDELINE

- Maximum speed
 STL25 to 50: v = 5 m/s

Loads, Forces and Moments

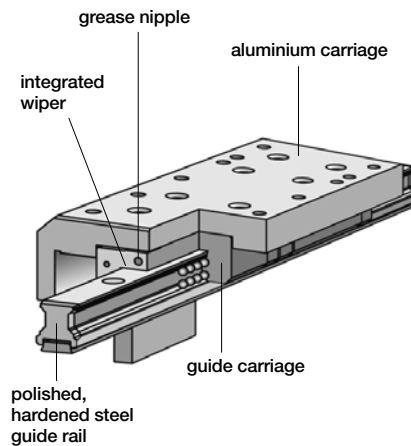
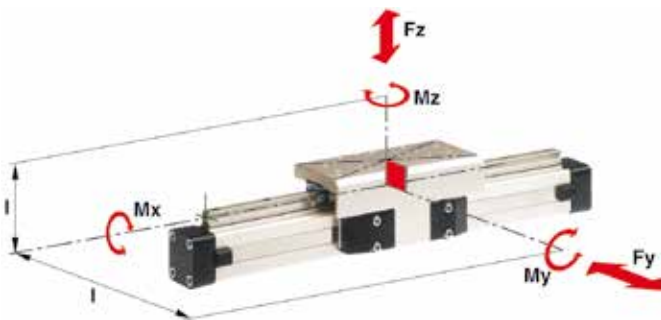

Technical Data

The table shows the maximal permissible loads. If multiple moments and forces act upon the cylinder simultaneously, the following equation applies:

$$\frac{M_x}{M_{x_{max}}} + \frac{M_y}{M_{y_{max}}} + \frac{M_z}{M_{z_{max}}} + \frac{F_y}{F_{y_{max}}} + \frac{F_z}{F_{z_{max}}} \leq 1$$

The sum of the loads should not exceed >1.

The table shows the maximum permissible values for light, shock-free operation, which must not be exceeded even under dynamic conditions.

For further technical information see catalogue P-A4P012GB

*** Please note:**

The mass of the carriage has to be added to the total moving mass when using the cushioning diagram

Series STL	For linear drive	Max. moments [Nm]			Max. loads [N]		Mass of linear drive with guide [kg]		Mass* of guide carriage [kg]	Order No. ** STARLINE Guide without cylinder
		Mx	My	Mz	Fy	Fz	with 0mm stroke	increase per 100 mm stroke		
STL25	OSP-L25	50	110	110	3100	3100	1.733	0.369	0.835	21112
STL32	OSP-L32	62	160	160	3100	3100	2.934	0.526	1.181	21113
STL40	OSP-L40	150	400	400	4000	7500	4.452	0.701	1.901	21114
STL50	OSP-L50						in progress			

** Please use this order pattern: Order-No. + "stroke in mm" (5 digits)
 Example: STARLINE guide D25mm, stroke 1000mm: 21112-01000

Mid-Section Support

Mid-section supports are required from a certain stroke length to prevent excessive deflection and vibration of the linear drive. The diagrams show the maximum permissible unsupported length in relation to loading. A distinction must be drawn between loading 1 and loading 2. Deflection of 0.5 mm max. between supports is permissible.

**Loading 1
 Top carrier**

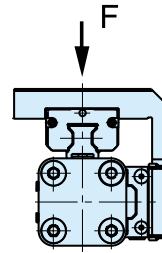

**Loading 2
 Side carrier**

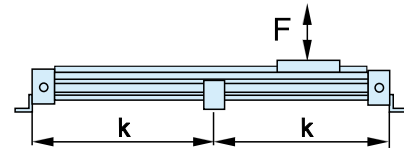
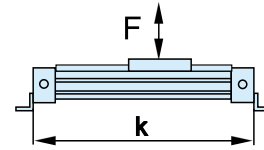
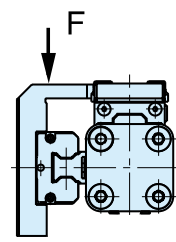

Permissible Unsupported Length STL25 to STL50

Permissible Unsupported Length STL25 to STL50

Loading 1 – Top carrier

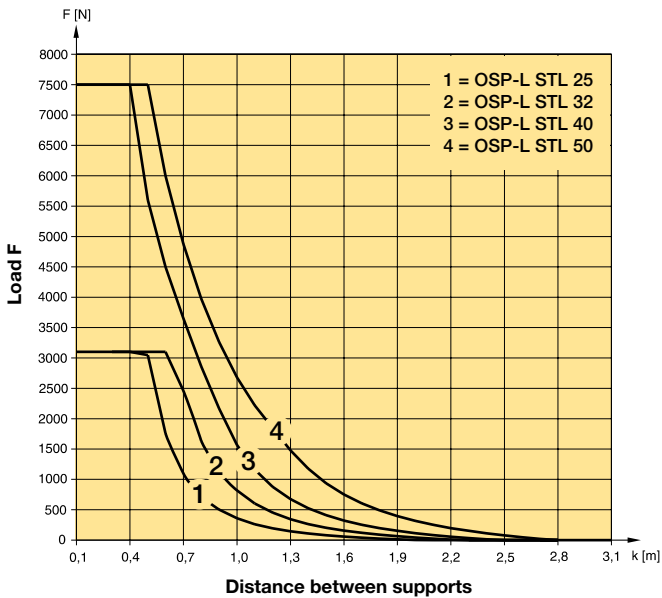

Loading 2 – Side carrier

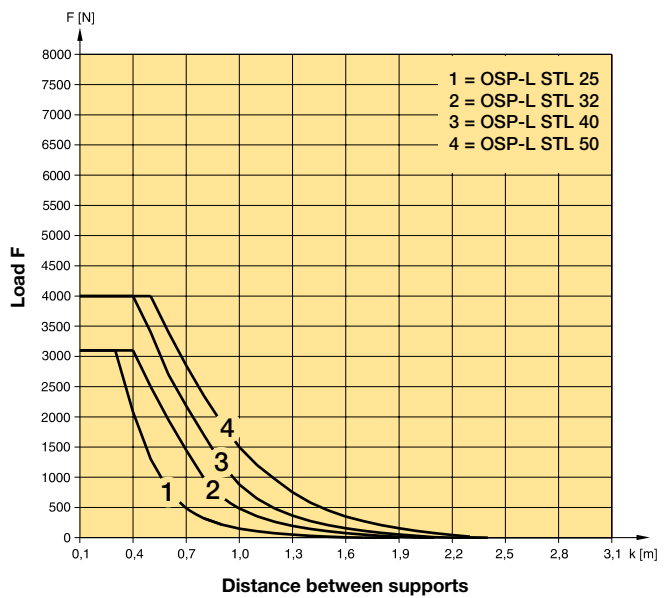

Note:

For speeds $v > 0.5$ m/s the distance between supports should not exceed 1 m.

Variable Stop

Type VS25 to VS50

Arrangement with two variable stops

The variable stop Type VS provides simple stroke limitation. It can be retrofitted and positioned anywhere along the stroke length.

For every cylinder diameter two types of shock absorber are available – see „Shock Absorber Selection“ below.

Mid-section supports and magnetic switches can still be fitted on the same side as the variable stop.

Depending on the application, two variable stops can be fitted if required.

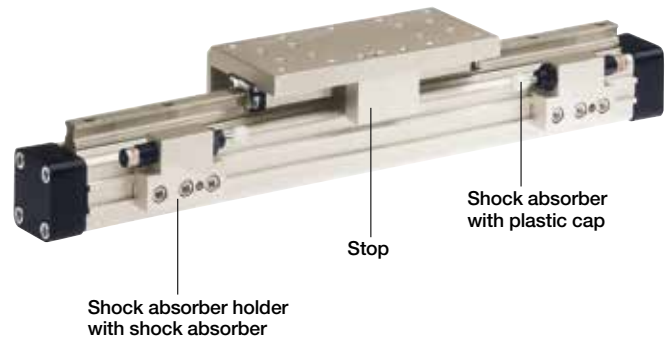

Shock Absorber Selection

The shock absorber is selected in dependence on the mass and speed.

The mass of the carrier itself must be taken into account.

Shock Absorber Selection in Dependence on Mass and Speed for Series OSP-L-STL25

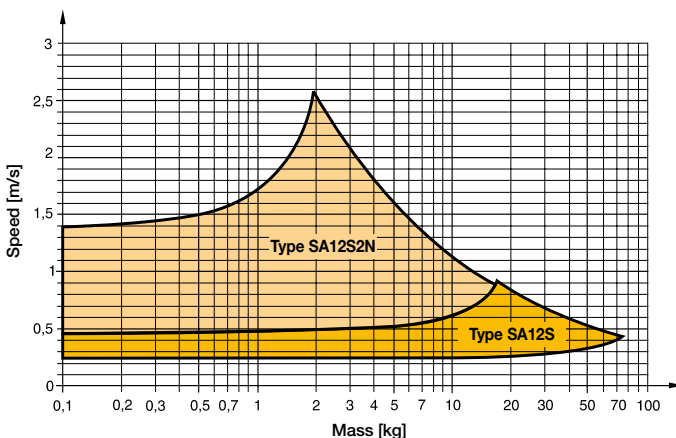

The values relate to an effective driving force of 250 N (6 bar)

Shock Absorber Selection in Dependence on Mass and Speed for Series OSP-L-STL32

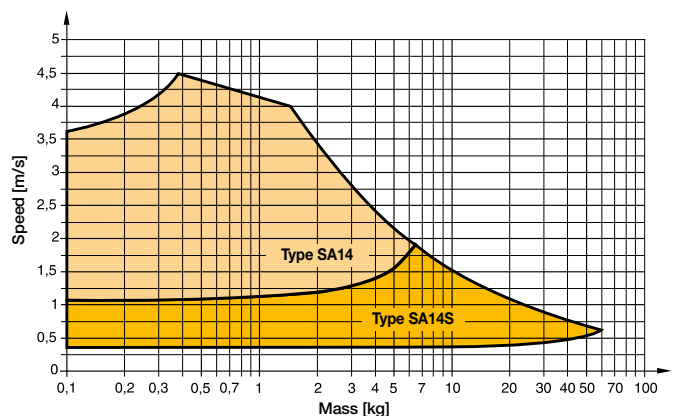

The values relate to an effective driving force of 420 N (6 bar)

Shock Absorber Selection in Dependence on Mass and Speed for Series OSP-L-STL40

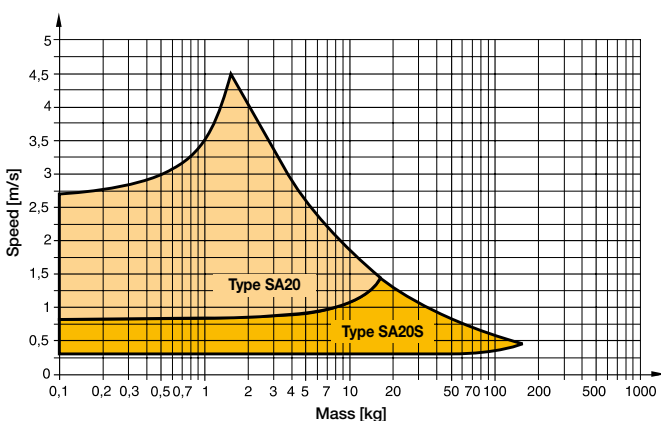

The values relate to an effective driving force of 640 N (6 bar)

Shock Absorber Selection in Dependence on Mass and Speed for Series OSP-L-STL50

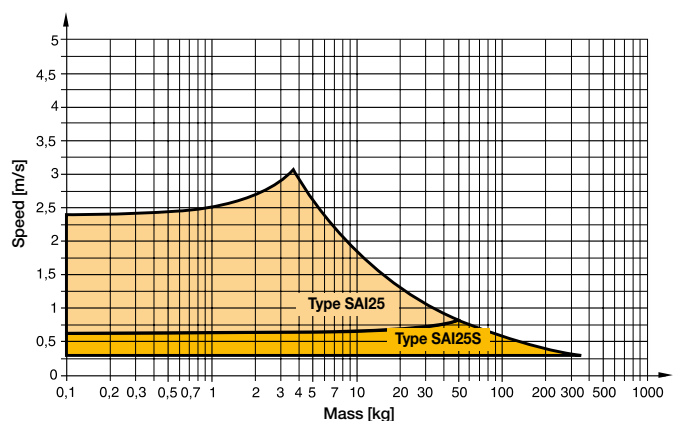

The values relate to an effective driving force of 1000 N (6 bar)

Variable Stop

Type VS25 to VS50

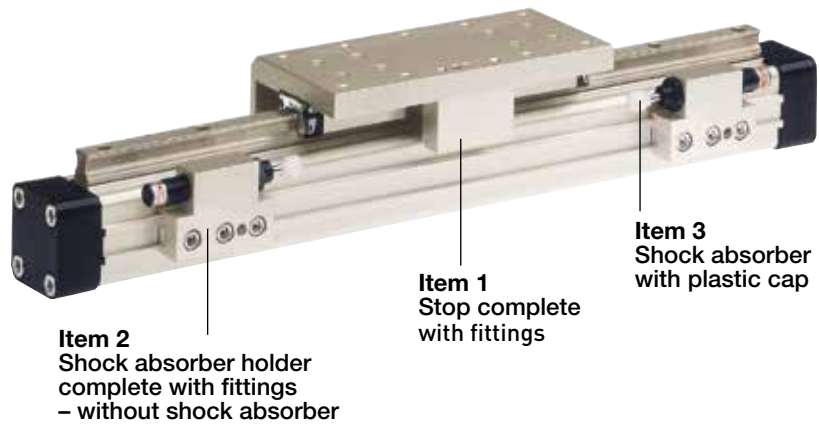

Order Instructions – Variable Stop Type VS25 to VS50

without cylinder and
without guide

Item	Description	Size							
		VS25		VS32		VS40		VS50	
		Type	Order-No.	Type	Order-No.	Type	Order-No.	Type	Order-No.
1	Stop, complete	-	21197FIL	-	21198FIL	-	21199FIL	in progress	
2	Shock absorber holder complete	-	21202FIL	-	21203FIL	-	21204FIL		
3 *	Shock absorber, soft	SA12S2N	7723FIL	SA14	7708FIL	SA20	7710FIL		
	Shock absorber, hard	SA12S	7707FIL	SA14S	7709FIL	SA20S	7711FIL		

* Shock absorber with plastic cap

Note: Order instructions for VS in combination with the Starline see page 177 pos.18

For further technical information see catalogue P-A4P012GB

Order Instructions - STARLINE

1-4	5+6	7	8	9	10	11	12-16	17	18	19	20	21	22	23	24	25
OSPL	25	0	0	0	0	0	01100	0	0	0	0	0	0	0	0	0

Piston-Ø																
25																
32																
40																
in progress																

Stroke																
in mm (5 digits)																

Piston Mounting																
0 without																

Measuring system																
0 without																

Screws																
0 standard																

Cushioning																
0 standard																
1 max. length																
2 variable stop complete VS soft left for Starline																
3 variable stop complete VS hard left for Starline,																
4 variable stop complete VS soft right for Starline																
5 variable stop complete VS hard right for Starline																
6 variable stop complete VS soft both sides for Starline																
7 variable stop complete VS hard both sides for Starline																

Cover / Cable Channel																
0 standard																
1 Cable channel																
2 Cable channel two-sided																

Version / Piston																
0 standard																
1 Tandem																

Air Connection																
0 standard																
1 end face																
2 both at one end																
3 left standard right end face																
4 right standard left end face																
A 3/2 Way valve VOE 24 V = Ø 25,32,40,50																
B 3/2 Way valve VOE 230 V- / 110 V= Ø 25,32,40,50																
C 3/2 Way valve VOE 48 V = Ø 25,32,40,50																
E 3/2 Way valve VOE 110 V- Ø 25,32,40,50																

Seals																
0 standard																

Lubrication																
0 standard																

End cap position																
0 l+r0° = in front																
1 l+r90° = underneath																
2 l+r180° = at the back																
3 l+r270° = same side as outerband																
4 l90° = underneath; r0° = in front																
5 l180° = at the back; r0° = in front																
6 l270° = same side as outerband; r0° = in front																
7 l0° = in front; r90° = underneath																
8 l180° = at the back; r90° = underneath																
9 l270° = same side as outerband; r90° = underneath																
A l0° = in front; r180° = at the back																
B l90° = underneath; r180° = at the back																
C l270° = same side as outerband; r180° = at the back																
D l0° = in front; r270° = same side as outerband																
E l90° = underneath; r270° = same side as outerband																
F l180° = at the back; r 270° = same side as outerband																

Guides/ Brakes/ Inversion																
0 without																
B Starline STL																

add. Guide Carriage																
0 without																
B Guide Carriage Starline STL																

End cap position (air connection)

Cylinder R (right end side)

Cylinder L (left end side)